



STAINLESS STEEL
HAND SINKS
 with SOAP and PAPER TOWEL DISPENSER



Item #: _____ **Qty #:** _____
Model #: _____
Project #: _____



7-PS-80



7-PS-79



7-PS-85

Includes Skirt



7-PS-69



For **A.D.A Compliant Units** with a paper towel dispenser, please **see Model 7-PS-41** on the **A.D.A. Hand Sink Specification Sheet**

Keyhole Bracket for easier installation and greater stability.

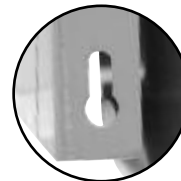

FEATURES:

- One piece **Deep Drawn** sink bowl design.
- Sink bowl is 10" x 14" x 5".
- All sink bowls have a large liberal radii with a minimum dimension of 2" and are rectangular in design for increased capacity.
- Keyhole wall mount bracket.
- Stainless steel basket drain 1-1/2" IPS.
- Towel dispenser with hinged towel box. Unit uses standard C-fold towels.
- Liquid Soap Dispenser.
- Splash mounted 4" O.C. gooseneck faucet furnished with aerator.

Specific Features:

- 7-PS-69** wrist handle faucet. Side support brackets included.
- 7-PS-69 & 7-PS-80** lever operated drain and built-in overflow with plastic overflow tube and spring clamps. P-Trap is 1 1/2".
- 7-PS-85** chrome plated 1 1/2" P-Trap & apron.

CONSTRUCTION:

- All TIG welded.
- Welded areas blended to match adjacent surfaces and to a satin finish.
- Die formed Countertop Edge with a No-Drip offset.
- One sheet of stainless steel- No Seams.

MATERIAL:

- Heavy gauge type 304 series stainless steel.
- Wall mounting bracket is Galvanized and of offset design.
- All fittings are brass / chrome plated unless otherwise indicated.

MECHANICAL:

- Faucet supply is 1/2" IPS male thread hot and cold.

Standard Faucet conforms to NSF 61 Standard 9. An optional faucet upgrade is required for compliance to AB 1953 Standards.

For Replacement Faucets & Upgrades, Drains & Accessories visit our website at www.advancetabco.com



Customer Service Available To Assist You 1-800-645-3166 8:30 am - 8:00 pm E.S.T.
 Email Orders To: customer@advancetabco.com. For Smart Fabrication™ Quotes, Email To: smartfab@advancetabco.com or Fax To: 631-586-2933

NEW YORK
 Fax: (631) 242-6900

GEORGIA
 Fax: (770) 775-5625

TEXAS
 Fax: (972) 932-4795

NEVADA
 Fax: (775) 972-1578

DIMENSIONS and SPECIFICATIONS

TOL Overall: ± .500" Interior: ± .250"

FITTINGS SUPPLIED AS SHOWN

ALL DIMENSIONS ARE TYPICAL

7-PS-69

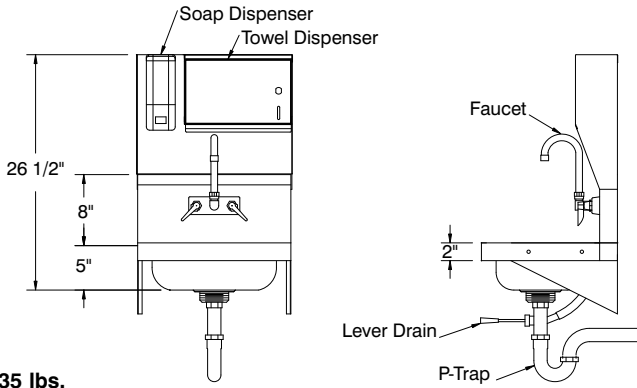

35 lbs.

7-PS-79

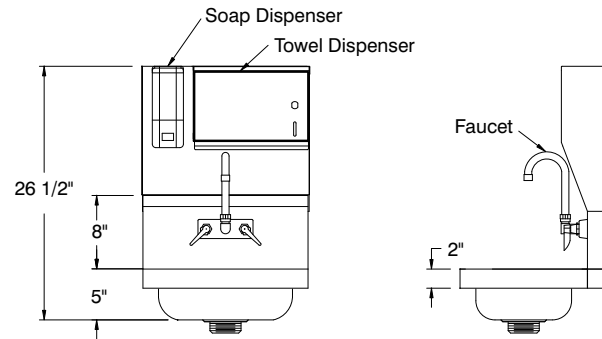

32 lbs.

7-PS-80

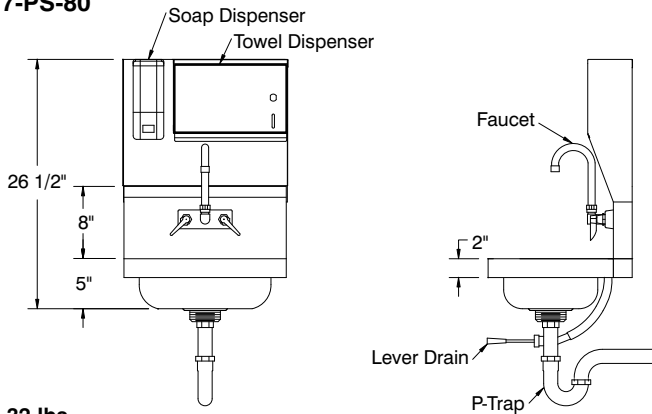

32 lbs.

7-PS-85

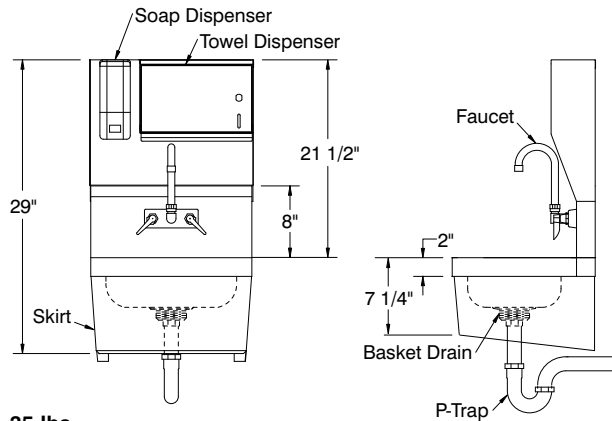

35 lbs.

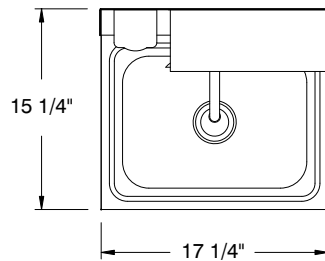

**TOP VIEW
WITH TOWEL
DISPENSER**

