



STAINLESS STEEL
**MICROWAVE
SHELVES**



**A Convenient Place for your
MICROWAVE!**



FOR TABLE MOUNTED MICROWAVE SHELVES:
Use **OTS Shelving** and add **TA-102** for Microwave
24" x 24" extension. Specify Right or Left.

OPTIONAL	Model #	Qty
Table Mounted Microwave Shelf	TA-102	
2" Hole with Grommet For Appliance Cord	TA-90	

Item #: _____ **Qty #:** _____

Model #: _____

Project #: _____

Wall Mounted

Width	Model #	W x L	Weight
18"	MS-18-24	18" x 24"	15 lbs.
24"	MS-24-24	24" x 24"	20 lbs.
24"	MS-24-36	24" x 36"	38 lbs.

CONSTRUCTION:

All TIG welded.

Exposed surfaces polished to a satin finish.

MATERIAL:

18 gauge stainless steel.

OPTIONAL TABLE MOUNTED UNITS:

Mounted on tubular supports and fastened to the top with expanding tubular connectors.

Please use *OTS Series Shelving* and add **TA-102** for 24" x 24" extension for table mounted version.

DETAILS and SPECIFICATIONS

TOL ± .500"

ALL DIMENSIONS ARE TYPICAL

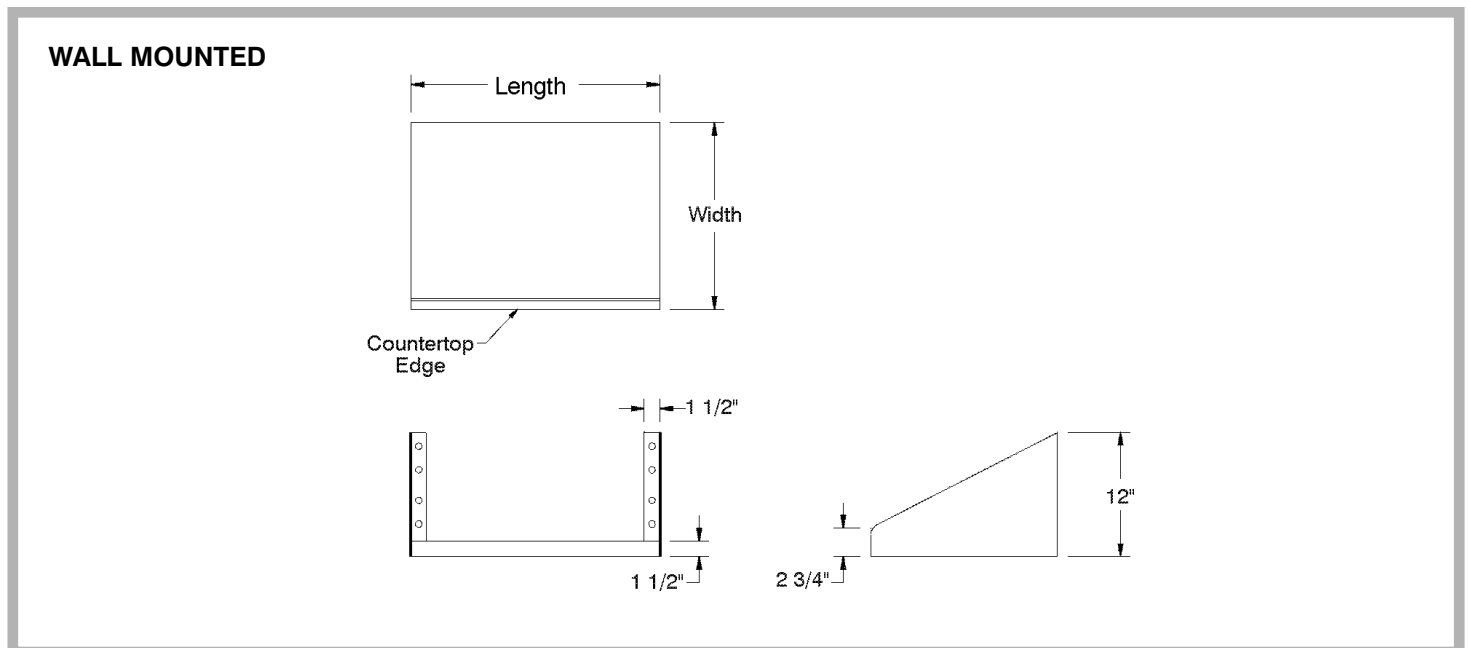

NEW YORK
(800) 645-3166
Fax: (631) 242-6900

GEORGIA
(800) 832-1218
Fax: (770) 775-5625

TEXAS
(800) 527-0353
Fax: (972) 932-4795

NEVADA
(800) 446-8684
Fax: (775) 972-1578