

Champion®

The Dishwashing Machine Specialists

Project _____
Item No. _____
Quantity _____

CG GLASSWASHER

STANDARD FEATURES

- Three built-in dispensing pumps
- Electric tank heater
- Glass activated on/off stop
- Stainless steel wash and rinse chamber
- Built-in controls
- Upper and lower wash and rinse spray system
- Polypropylene conveyor

CG

Rotary Type Series
Fully Automatic
Glasswashing Machine

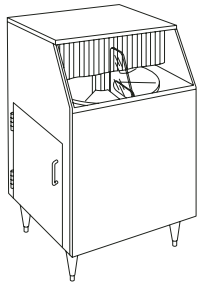

CG2
Access door left
Counter-clockwise rotation

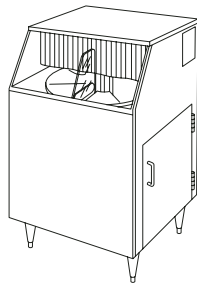

CG1
Access door right
Clockwise rotation

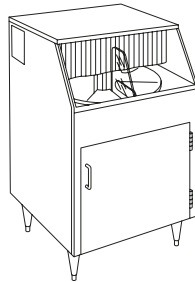

CG
Access door front
Clockwise rotation



OPTIONS & ACCESSORIES

- Drain tray and waste collector (CG-70A)
- Casters; set of four – 2 locking, 2 regular
- Hand sink and wet waste receiver (CG46C)
- Wash down hose

SPECIFIER STATEMENT

Specified unit will be Champion model CG Rotary Type, fully automatic glasswasher.

Unit will have detergent pump, sanitizer pump and rinse aid pump, standard upper and lower wash/rinse arms, wash tank heater, cold water final rinse, polypropylene conveyor, splash curtains, double-walled construction, storage space for three 1-gallon containers.

Champion Industries, Inc.
P. O. Box 4149, Winston-Salem, NC 27115
Tel: 800/532-8591 Fax: 336/661-1979
www.championindustries.com

Rotary Type Series
Fully Automatic
Glasswashing Machine

The Dishwashing Machine Specialists

Dimensions shown in inches and [millimeters]

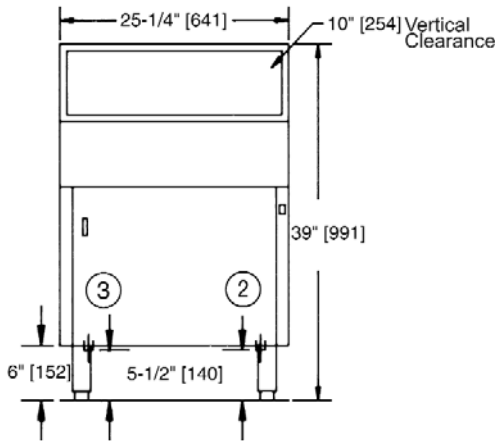

Front View

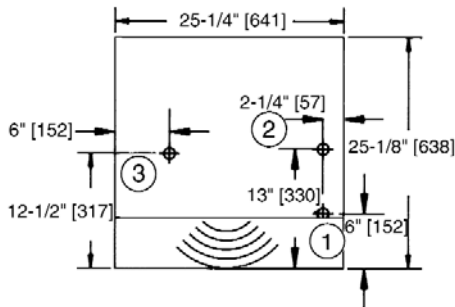

Plan View

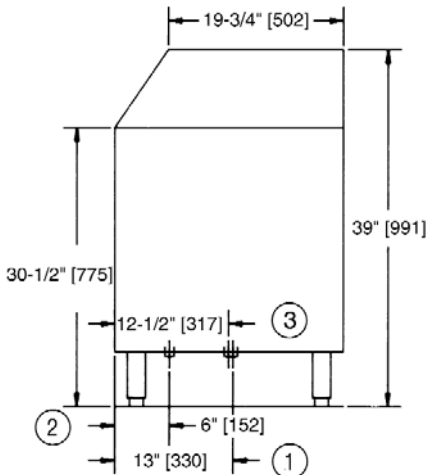

Side View

Utilities

	*Electrical 208-230/60/1, 15 AMP
1 Hot Water	1/2" IPS. Flow pressure 25-95 psi
2 Cold Water	1/2" IPS. Flow pressure 25-95 psi
3 Drain	1-1/2" tailpiece. Connect to drain size according to local plumbing code.

* NOTE: CG models supplied with 4 ft. plug-in cord (NEMA 6-15P).

Warning: Plumbing and electrical connections should be made by qualified workmen who will observe all the applicable plumbing, sanitary and safety codes.

	Uncrated	Crated
Height*	39"	46-1/2"
Width	25-1/4"	27"
Depth	25-1/8"	27-1/2"
Ship Wt. Lbs.	156	176

*Adjustable foot height 1-3/4"

SPECIFICATIONS

Capacity (hr.)	2-1/2" glasses/hr.	1000
Conveyor Movement	CG (access door front)	Clockwise
	CG1 (access door right)	Clockwise
	CG2 (access door left)	Counter-clockwise
Water consumption	Cold Water (approx.)	2.8 gpm
	Hot Water (initial fill)	3 gpm
	(Max. use - approx. 10 gph)	
Temperatures °F	Inlet water (hot)	140-160
	Inlet water (cold)	75
Heating	Tank heat, electric, (kW)	3
Clearance	Through machine (inches)	10

Due to an ongoing value analysis program at Champion, specifications contained in this catalog are subject to change without notice.