



||| a Standex company

Item \_\_\_\_\_

## CURVED GLASS REFRIGERATED DELI CASE

MODEL CGR5048CD  
CGR5948CD  
CGR7748CD



*Sleek curved-glass styling blends with traditional design elements to maximize performance. Cases are available in lengths of 50", 59", and 77". Designed for continuous case line-ups without middle end glass.*

### STANDARD FEATURES

- Curved glass styling.
- Adjustable full-length stainless steel lighted mezzanine shelf. Shelf is adjustable up and down and can also be tilted in three positions.
- Removable rear wrapping board.
- Tempered thermopane tilt-out front glass for easy cleaning. Front glass is curved for high visual product displays.
- Tempered thermopane glass ends and doors.
- Removable sliding rear doors, shelf light, shelf supports, and shelf.
- Shielded top light and shelf light.
- Steel base construction with a choice of six standard laminates on base. Other finishes optional.
- Condenser air filter on self-contained units.
- UL Safety and UL Sanitation Listed.
- Thermometer.
- Removable, scratch-resistant, rustproof white display deck.
- Condensate evaporator provided for a totally self-contained system.
- Oversized coil and low-velocity fan system maintains high humidity and product freshness.
- Easy clean, rustproof insulated evaporator coil compartment.
- Easily accessible light switch and adjustable temperature control.
- Average case temperature of 36° to 38° is maintained.
- Rear access of the refrigeration system for quick and easy service.
- Black trim.
- Designed for continuous line-ups.
- 134A Refrigerant.

# CURVED GLASS REFRIGERATED DELI CASE

## OPTIONAL ACCESSORIES:

- \*Special Base Finish
- \*Additional Mezzanine Shelf
- \*Cord & Plug (Self-Contained Models Only)
- \*Remote Refrigeration
- \*Reflective Ends
- \*White or Mirrored Interior Ends With Laminated Exterior
- \*Reflective Rear Doors
- \*Casters/Cord & Plug Included (Self-Contained Models Only)
- \*Legs
- \*Top Cutting Board, White
- \*Package Shelf
- \*Light Below Package Shelf
- \*Front Glass and Rear Door Locks
- \*Joining Kit for Continuous Line-ups
- \*Scale Platform
- \*Step Riser or Pan Holder

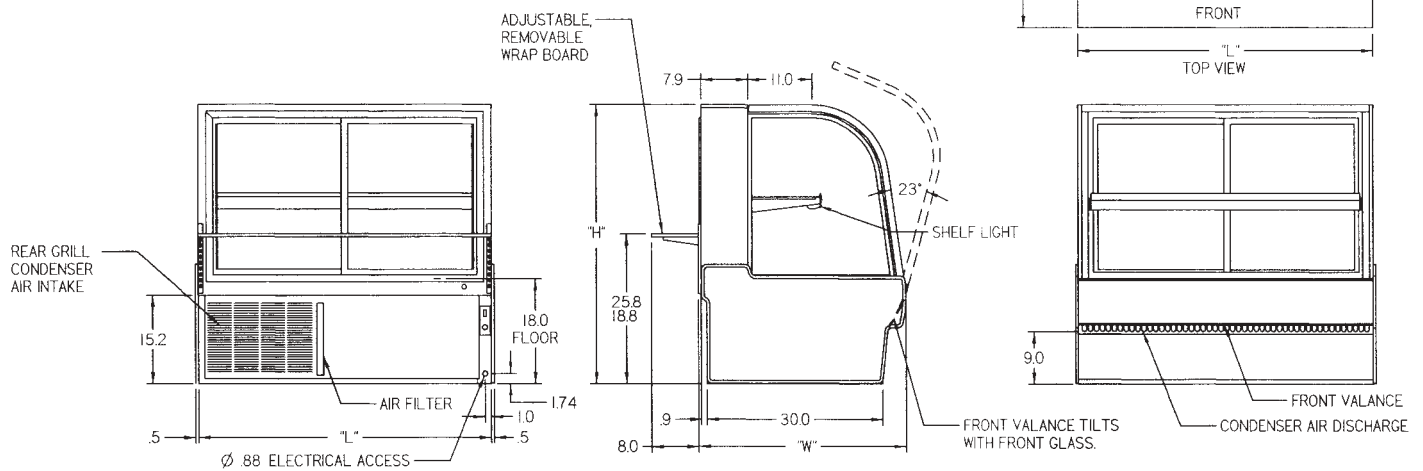

## SPECIFICATIONS:

Model	Dimensions L W H	Shipping Weight (lbs)	Capacity (Step Risers)	Self-Contained 120/60/1	Remote 120/60/1
CGR5048CD	50.13" x 35.31" x 48"	620	3	1/2 HP - 10.5 AMPS	2.3 AMPS
CGR5948CD	59.13" x 35.31" x 48"	650	4	1/2 HP - 11.6 AMPS	2.5 AMPS
CGR7748CD	77.13" x 35.31" x 48"	870	6	3/4 HP - 14.2 AMPS	3.3 AMPS

- Refrigerated cases are designed to operate in a maximum environment of 75° ambient and 55% relative humidity.
- Due to continuing engineering improvements, specifications are subject to change without notice.



## Look to Federal for Innovative Merchandising



**a Standex company**

**Federal Industries**  
**A Standex Company**  
**215 Federal Avenue**  
**Belleville WI 53508-0290**  
**Phone: 800-356-4206**  
**Fax: 608-424-3234**  
**Email: [geninfo@federalind.com](mailto:geninfo@federalind.com)**  
**Web Site: [www.federalind.com](http://www.federalind.com)**