

Conserver XL2

Project _____
 Item _____
 Quantity _____
 CSI Section 11400 _____
 Approval _____
 Date _____

Models

- Conserver XL2 Conserver XL2-CMR Conserver XL2-CML



Standard Features

- Universal timer
- Built in waste accumulator
- 3" (76 mm) stainless steel adjustable bullet feet
- Delimer switch for easy removal of hard water deposits
- Removable scrap screen
- Three selectable timer cycles
- Air gap instead of vacuum breaker
- Door safety switch
- Convenient top mounted controls
- Auto start
- Interchangeable stainless steel arms
- Internal sump saves space

Mandatory Specs

- Specify voltage

Optional Features

- Solid Bowl Option

Accessory Items

- 36 Compartment Racks
 (4-1/8", 5-5/8", or 7")
 (105 mm, 143 mm, 178 mm)
- Combination Rack
- Peg Rack
- Sanitizer Alarm
- Scaltrol
- Water Hammer Arrestor

Specifications

Uses 1.5 gallons (6 liters) of water per rack

74 rack per hour

Single point electrical connection

Self-draining stainless steel pump eliminates soil/detergent carryover between wash and rinse cycles

Dump and fill feature disposes of dirty water, replacing it with a fresh water rinse every cycle

Field convertible from straight to corner and corner to straight for flexible installations and applications.

Dual-point drain connections allow for versatile installations

17-1/4" (438 mm) vertical inside clearance

3 built-in dispensing pumps for detergent, rinse agent and sanitizer are controlled by individual priming switches

Fully automatic timed cycles - 90 seconds, 3 minutes or 5 minutes

Accommodates 2 racks side by side



Conservex XL2

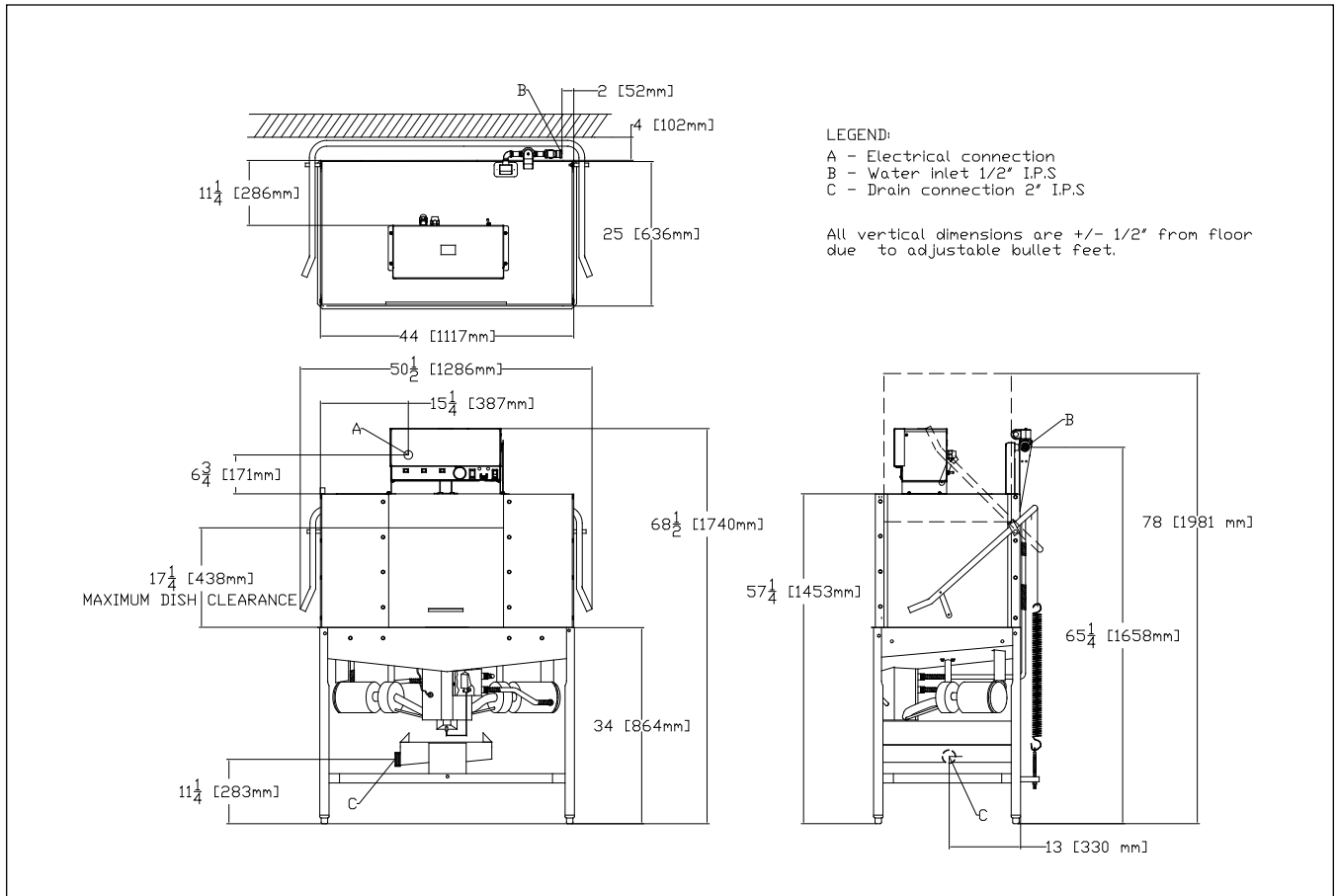

DIMENSIONS--INCHES (mm)--STANDARD MODEL

MODEL NO.	SIZE			DRAIN HEIGHT	SHIPPING INFO			DIMENSIONS		
	HEIGHT	WIDTH	DEPTH		WEIGHT	CLASS	CUBE	HEIGHT	WIDTH	DEPTH
Conservex XL2	68-1/2" (1740 mm)	50-1/2" (1286 mm)	25" (636 mm)	11-1/4" (283 mm)	560 lbs (254 kg)	92.5	74.8" cu. ft.	78" (1981 mm)	55" (1397 mm)	30" (762 mm)

REQUIREMENTS

MODEL	ELECTRICAL REQUIREMENT	SERVICE BREAKER SIZE
Conservex XL2	115v/60~1ø-22.8A	30A

WATER REQUIREMENTS	MINIMUM	RECOMMENDED
INLET TEMPERATURE	120°F 48.9°C	140°F 60.0°C
WASH OPERATING TEMPERATURES	120°F 48.9°C	140°F 60.0°C
RINSE OPERATING TEMPERATURES	120°F 48.9°C	140°F 60.0°C

PERFORMANCE CAPABILITIES

Flow Pressure (PSI)	15-25
Wash Pump Motor Horsepower	3/4
Pump Capacity (GPM)	55
Minimum Chlorine Required (PPM)	50

HOW TO SPECIFY- EXAMPLE:

Conservex XL2 - Chemical sanitizing, 115 volt, 1 phase

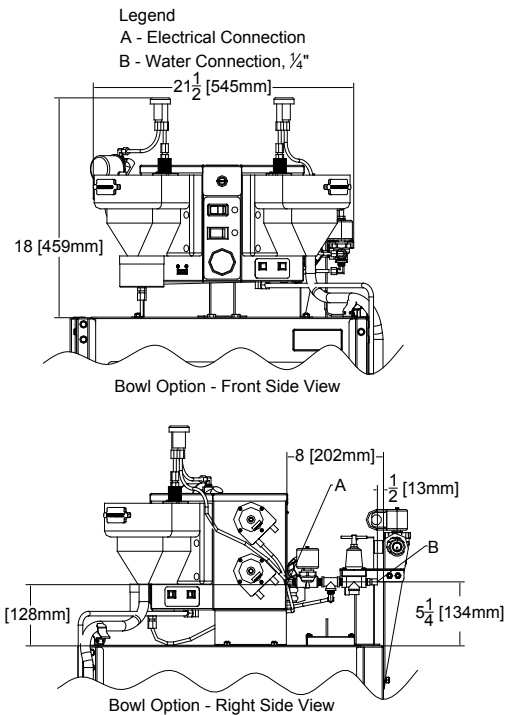

Consolver XL2 - CMR

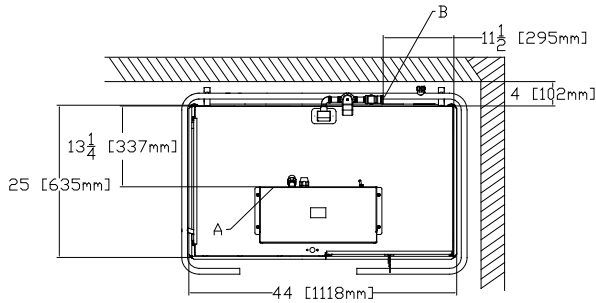

LEGEND:
 A - Electrical connection
 B - Water inlet 1/2" I.P.S.
 C - Drain connection 2" I.P.S.

All vertical dimensions are +/- 1/2" from floor due to adjustable bullet feet.

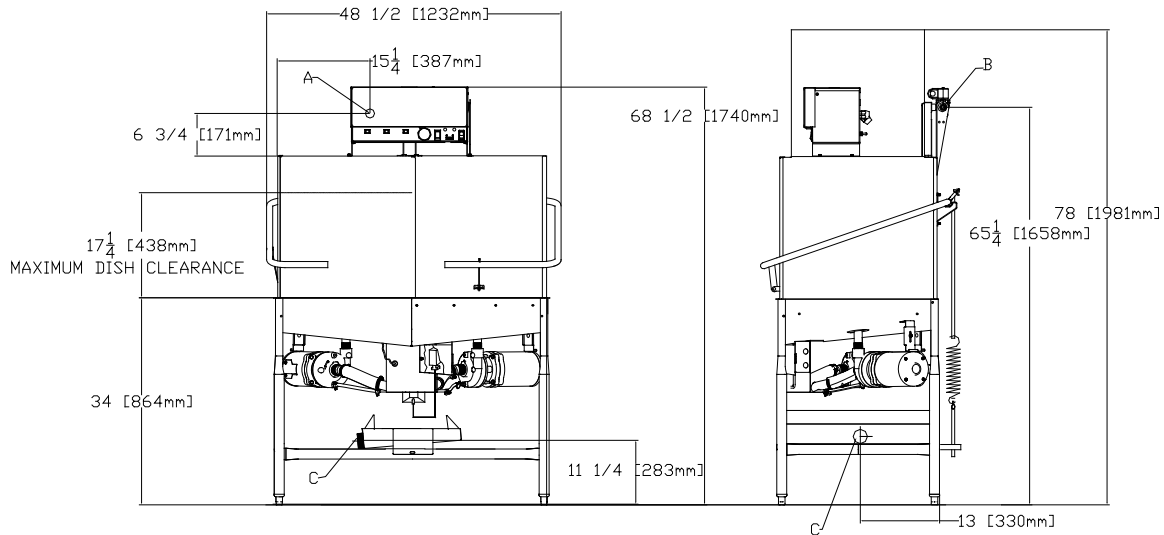

DIMENSIONS--INCHES (mm)--STANDARD MODEL

MODEL NO.	SIZE			DRAIN HEIGHT	SHIPPING INFO			DIMENSIONS		
	HEIGHT	WIDTH	DEPTH		WEIGHT	CLASS	CUBE	HEIGHT	WIDTH	DEPTH
Consolver XL2-CMR	68-1/2" (1740 mm)	48-1/2" (1232 mm)	25" (635 mm)	11-1/4" (283 mm)	560 lbs (254 kg)	92.5	74.8" cu. ft.	78" (1981 mm)	55" (1397 mm)	30" (762 mm)

REQUIREMENTS

MODEL	ELECTRICAL REQUIREMENT	SERVICE BREAKER SIZE
Consolver XL2-CMR	115v/60~1ø-22.8A	30A

WATER REQUIREMENTS	MINIMUM	RECOMMENDED
INLET TEMPERATURE	120°F 49°C	140°F 60°C
WASH OPERATING TEMPERATURES	120°F 49°C	140°F 60°C
RINSE OPERATING TEMPERATURES	120°F 49°C	140°F 60°C

PERFORMANCE CAPABILITIES

Flow Pressure (PSI)	15-25
Wash Pump Motor Horsepower	3/4
Pump Capacity (GPM)	55
Minimum Chlorine Required (PPM)	50

HOW TO SPECIFY - EXAMPLE:

Consolver XL2-CMR - Chemical sanitizing, 115 volt, 1 phase

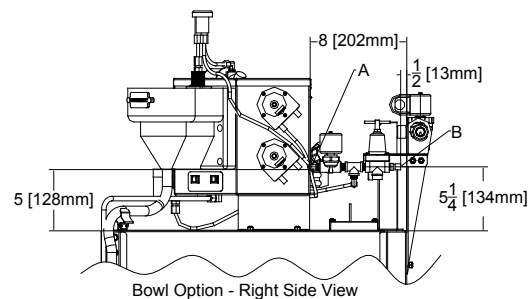
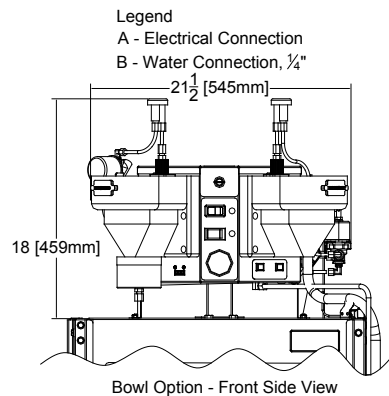



Jackson

Conservar XL2-CML

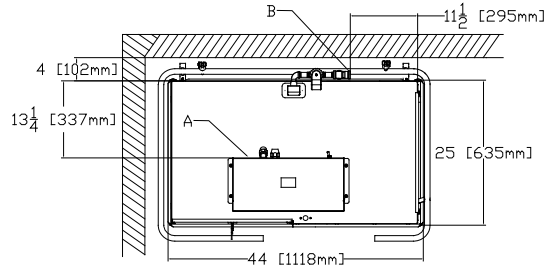

LEGEND:
 A - Electrical connection
 B - Water inlet 1/2" I.P.S.
 C - Drain connection 2" I.P.S.

All vertical dimensions are +/- 1/2" from floor due to adjustable bullet feet.

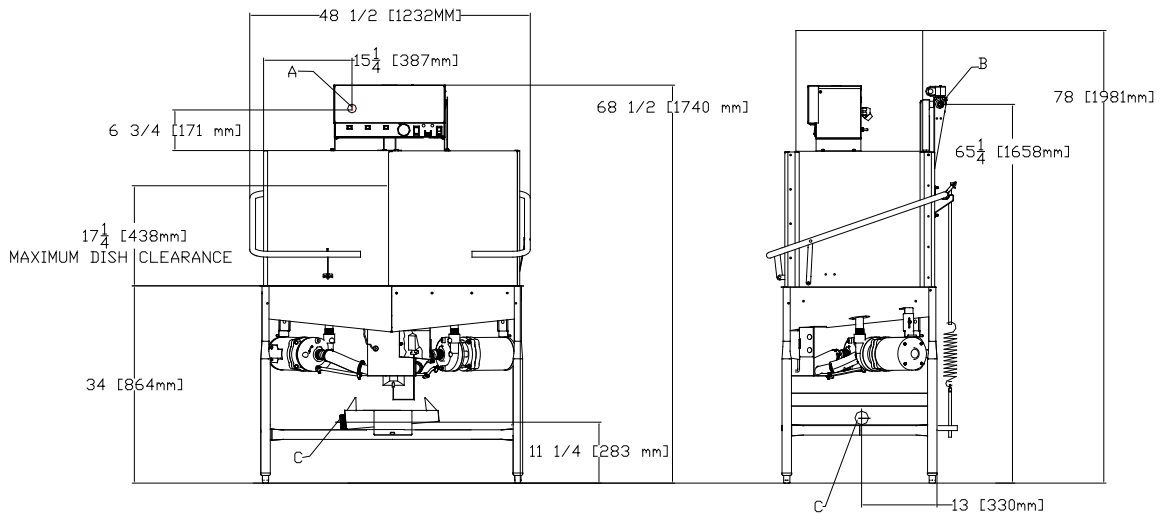

DIMENSIONS--INCHES (mm)--STANDARD MODEL

MODEL NO.	SIZE			DRAIN HEIGHT	SHIPPING INFO			DIMENSIONS		
	HEIGHT	WIDTH	DEPTH		WEIGHT	CLASS	CUBE	HEIGHT	WIDTH	DEPTH
Conservar XL2-CML	68-1/2" (1740 mm)	48-1/2" (1232 mm)	25" (635 mm)	11-1/4" (283 mm)	560 lbs (254 kg)	92.5	74.8" cu. ft.	78" (1981 mm)	55" (1397 mm)	30" (762 mm)

REQUIREMENTS

MODEL	ELECTRICAL REQUIREMENT	SERVICE BREAKER SIZE
Conservar XL2-CML	115v/60~1ø-22.8A	30A

WATER REQUIREMENTS	MINIMUM	RECOMMENDED
INLET TEMPERATURE	120°F 49°C	140°F 60°C
WASH OPERATING TEMPERATURES	120°F 49°C	140°F 60°C
RINSE OPERATING TEMPERATURES	120°F 49°C	140°F 60°C

PERFORMANCE CAPABILITIES

Flow Pressure (PSI)	15-25
Wash Pump Motor Horsepower	3/4
Pump Capacity (GPM)	55
Minimum Chlorine Required (PPM)	50

HOW TO SPECIFY - EXAMPLE:

Conservar XL2-CML - Chemical sanitizing, 115 volt, 1 phase

Legend
 A - Electrical Connection
 B - Water Connection, 1/4"

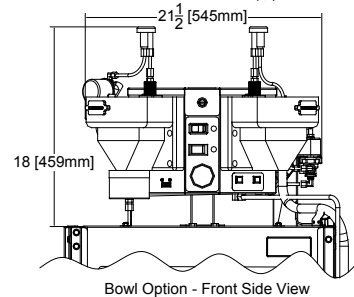

Bowl Option - Front Side View

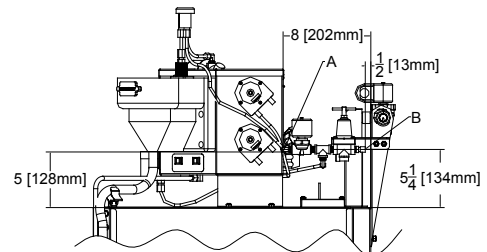

Bowl Option - Right Side View

Highway 25E
 P. O. Box 1060
 Barbourville, KY 40906

Tel: 606-523-9795
 Tel: 1-888-800-5672
 Fax: 606-523-9196
 E-mail: info@jacksonmsc.com

www.jacksonmsc.com
 07610-003-30-04 C (1/07)

Enodis