



Project:

Item Number:

Quantity:

REFRIGERATED DISPLAY CABINETS



Drop-in Cabinet

Curved Cabinet

Cubed Cabinet

Refrigerated Display Cabinets

DESCRIPTION

Vollrath's refrigerated drop-in and countertop display cabinets enhance the presentation of cold food items. Sliding rear doors enable easy access for selling, refilling, changing displays and end-of-day cleaning.

WARRANTY: All models shown come with Vollrath's standard warranty against defects in materials and workmanship. For full warranty details, please refer to the Vollrath Equipment and Smallwares Catalog.

Agency Listings



Due to continued product improvement, please consult www.vollrathco.com for current product specifications.

MODELS

- 40842 RDE7136 36" Drop-in Display Cabinet
- 40843 RDE7148 48" Drop-in Display Cabinet
- 40844 RDE7160 60" Drop-in Display Cabinet
- 40852 RDE8136 36" Curved Glass Display Cabinet
- 40853 RDE8148 48" Curved Glass Display Cabinet
- 40854 RDE8160 60" Curved Glass Display Cabinet
- 40862 RDE8236 36" Cubed Glass Display Cabinet
- 40863 RDE8248 48" Cubed Glass Display Cabinet
- 40864 RDE8260 60" Cubed Glass Display Cabinet

FEATURES

- Inside lighting strips located both at the top of the cabinet and underneath the upper shelf create optimum food display throughout cabinet
- Dual fans circulate air throughout unit to ensure even temperature control
- Triple-glazed front glass gives added strength and insulation
- Drop-in and curved cabinets have two shelves. The cubed cabinet has 3 shelves.
- Lift-and-remove rear sliding doors for easy display changes and end of day cleaning
- Digitally controlled thermostat for precise and consistent settings
- 36° - 46° F (2° to 21° C) temperature range
- Drop-in models can also be used as freestanding countertop units
- 6 ft. (1.8 m) 120v cord and plug
- Note: these items must ship by truck

CLEARANCE REQUIREMENTS

- Drop-in cabinets require a minimum of 6" (15.2 cm) of non-combustible countertop to support the unit and a minimum of 6" (15.2 cm) clearance on all sides of the drop-in for proper air circulation.
- Countertop cabinets require a minimum of 6" (15.2 cm) between the equipment and any surrounding walls. Surrounding walls must be made of non-combustible materials.

Approvals	Date



www.vollrathco.com

The Vollrath Company, L.L.C.
1236 North 18th Street
Sheboygan, WI 53081-3201 U.S.A.
Customer Service: 800.628.0830
Canada Customer Service: 800.695.8560
Main Fax: 800.752.5620 or 920.459.6573

Technical Services: 800.628.0832
Technical Services Fax: 920.459.5462

REFRIGERATED DISPLAY CABINETS

MODELS	40842 RDE7136 36" Drop-in Display Cabinet	40854 RDE8160 60" Curved Glass Display Cabinet
	40843 RDE7148 48" Drop-in Display Cabinet	40862 RDE8236 36" Cubed Glass Display Cabinet
	40844 RDE7160 60" Drop-in Display Cabinet	40863 RDE8248 48" Cubed Glass Display Cabinet
	40852 RDE8136 36" Curved Glass Display Cabinet	40864 RDE8260 60" Cubed Glass Display Cabinet
	40853 RDE8148 48" Curved Glass Display Cabinet	

DIMENSIONS

Dimensions shown in inches (cm).

Drop-in Display Cabinets

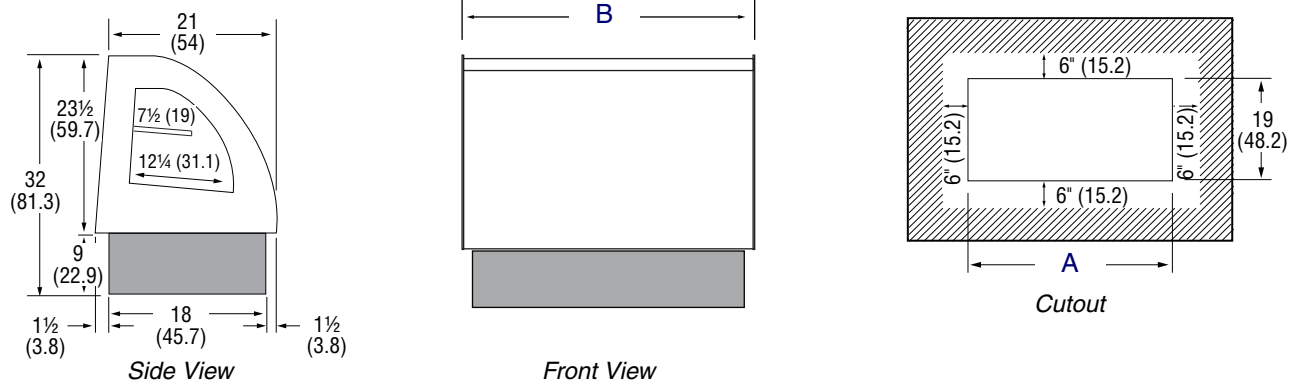

Curved Display Cabinets

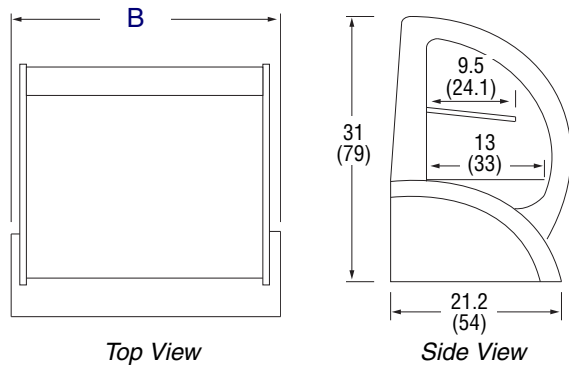

Cubed Display Cabinets

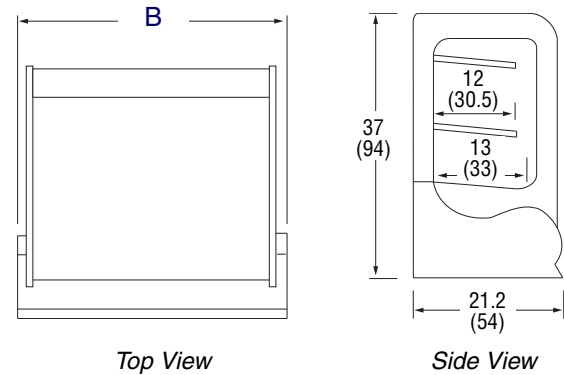

SPECIFICATIONS

Item	(A) Cutout Width	(B) Width	HP	Volts	Amps	Watts	Weight lb (kg)	Plug
40842	34 (86.3)	36 (91.4)	1/5	120V AC	3.4	400	210 (95.3)	5-15P
40843	45 (114.3)	48 (121.9)	1/4	120V AC	4.2	510	250 (113.4)	5-15P
40844	58 (147.3)	60 (152)	3/4	120V AC	4.4	530	274 (124.3)	5-15P
40852	-	35 7/16 (90)	1/5	120V AC	3.6	430	190 (86.2)	5-15P
40853	-	47 3/16 (119.9)	1/4	120V AC	4.6	550	235 (106.6)	5-15P
40854	-	59 (149.9)	1/4	120V AC	4.9	585	271 (122.9)	5-15P
40862	-	35 7/16 (90)	1/4	120V AC	3.9	470	230 (104.3)	5-15P
40863	-	47 3/16 (119.9)	3/8	120V AC	5.0	600	281 (127.5)	5-15P
40864	-	59 (149.9)	3/8	120V AC	6.0	725	322 (146)	5-15P

Receptacle

