



**John
BOOS**
Since 1887

ITEM #: _____ QTY: _____
 MODEL #: _____
 PROJECT NAME: _____

012218

3601 S. Banker St. Effingham, IL 62401 • P.O. BOX 609 • Ph: (888) 431-2667 • Fax: (800) 433-2667

"E1S8-2D" - 1 COMPARTMENT "E-SERIES" SINKS

WITH 2 DRAIN BOARDS AND GALVANIZED LEGS



FEATURES:

- 18GA STAINLESS STEEL
- TYPE 300 STAINLESS STEEL WITH #4 POLISH, SATIN FINISH
- 12" AND 14" DEEP BOWLS
- ALL CORNERS, BOTH VERTICAL AND HORIZONTAL, COVED AT 3/4" RADIUS
- BOTTOMS OF BOWLS FORMED FOR DRAINAGE TO 3-1/2" DIAMETER DIE STAMPED OPENING
- FULL LENGTH 10" HIGH BOXED BACKSPLASH, WITH 2" RETURN TO WALL AT 45 DEGREE AND 1" TILE EDGE
- 1" FAUCET HOLES IN BACKSPLASH
- ALL OUTSIDE CORNERS OF ASSEMBLY ARE BULLNOSED TO PROVIDE SAFE, CLEAN, AND POLISHED EDGE
- STANDARD GALVANIZED LEGS 1-5/8" DIAMETER

CONSTRUCTION:

- TOP: STAINLESS STEEL SINKS ARE TIG WELDED, EXPOSED WELDS ARE POLISHED TO MATCH ADJACENT SURFACE
- BASE: GALVANIZED STEEL

MATERIAL:

- BOWLS & TOP: 18GA TYPE 300 STAINLESS STEEL WITH #4 POLISH, SATIN FINISH
- LEGS: 1-5/8" ROUND O.D. GALVANIZED STEEL
- GUSSETS: GALVANIZED STEEL
- FEET: 1" PLASTIC BULLET FEET

12" DEEP - 1 COMP SINKS - 18GA

MODEL	BOWL SIZE (W ₁ X L ₁ X D ₁)	QTY
E1S8-1620-12T18	16" X 20" X 12"	
E1S8-18-12T18	18" X 18" X 12"	

14" DEEP - 1 COMP SINKS - 18GA

MODEL	BOWL SIZE (W ₁ X L ₁ X D ₁)	QTY
E1S8-15-14T15	15" X 15" X 14"	
E1S8-1824-14T24	18" X 24" X 14"	
E1S8-24-14T24	24" X 24" X 14"	



E1S8-1824-14T24

DETAILED SPECIFICATIONS

12" DEEP - SINK DIMENSIONS

A	D ₁
14"	12"

14" DEEP - SINK DIMENSIONS

A	D ₁
16"	14"

BOWL DIMENSIONS

W ₁ X L ₁	L	B	W
15" X 15"	20-1/2"	10-1/2"	45"
16" X 20"	25-1/2"	13"	52"
18" X 18"	23-1/2"	12"	54"
18" X 24"	29-1/2"	15"	66"
24" X 24"	29-1/2"	15"	72"

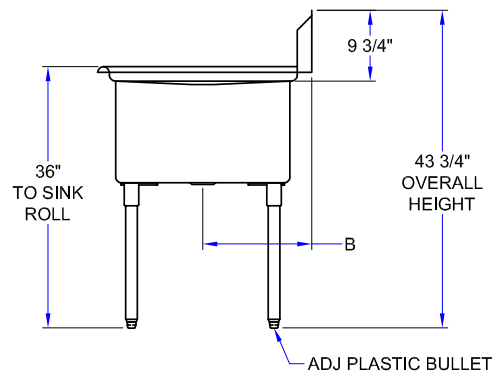
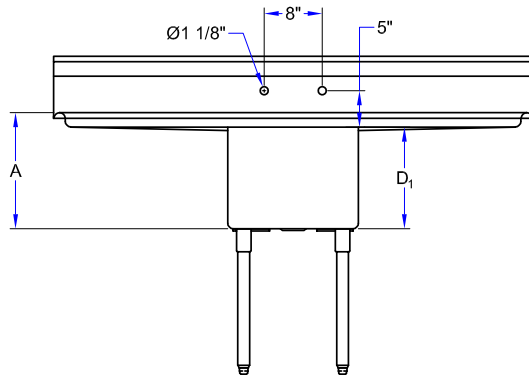
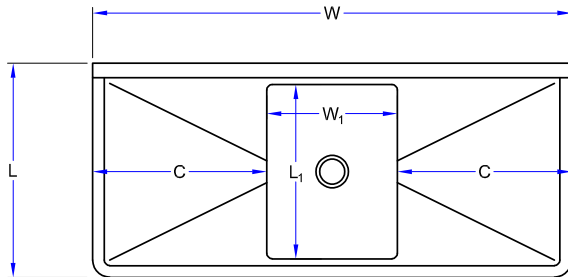

12" DEEP - 1 COMP SINKS - 18GA

MODEL	BOWL SIZE (W ₁ X L ₁ X D ₁)	DIMENSIONS (W X L)	DRAIN BOARDS (C)	WEIGHT (LBS)
E1S8-1620-12T18	16" X 20" X 12"	52" X 25-1/2"	18"	55
E1S8-18-12T18	18" X 18" X 12"	54" X 23-1/2"	18"	54

14" DEEP - 1 COMP SINKS - 18GA

MODEL	BOWL SIZE (W ₁ X L ₁ X D ₁)	DIMENSIONS (W X L)	DRAIN BOARDS (C)	WEIGHT (LBS)
E1S8-15-14T15	15" X 15" X 14"	45" X 20-1/2"	15"	42
E1S8-1824-14T24	18" X 24" X 14"	66" X 29-1/2"	24"	71
E1S8-24-14T24	24" X 24" X 14"	72" X 29-1/2"	24"	76

SOME UNITS SHIP UNASSEMBLED FOR REDUCED SHIPPING COST. ALL DIMENSIONS ARE TYPICAL. TOLERANCE +/- .500"
 John Boos & Co. is constantly engaged in a program of improving products and therefore reserves the right to change specifications without prior notice.



3601 S. Banker St. • Effingham, IL 62401 • PO BOX 609 • quotes@johnboos.com

011018

Boos
locks

AQ AutoQuotes

www.johnboos.com

151