

# AMERICAN RANGE

QUALITY LINE OF COOKING EQUIPMENT

## AHS HORIZONTAL CHICKEN BROILERS

### STANDARD FEATURES

- Stainless Steel rugged exterior body.
- Large 27" or 36" deep broiling surface.
- Round rod non-stick cooking top grates specially designed for chicken broiling.
- High BTU for even heat distribution assures fully cooked chickens.
- Open bottom grate design allows continuous up draft for optimum fuel combustion.
- Rotisserie option allows more cooking production with minimal operator attention.
- Heavy duty liner protects interior from burn out.
- Requires either legs or stand.
- One year limited warranty, parts and labor.



AHS-4836  
Shown with optional stand



The American Range AHS Horizontal Chicken Broiler brings the flavor and excitement of backyard chicken broiling to the commercial kitchen. Design engineered with an open bottom grate for optimal fuel combustion, and round rod non-stick cooking grates, the high BTU output of the AHS assures even heat distribution for fully cooked chickens.

The AHS features a stainless steel rugged exterior body and heavy duty liner to protect the interior from burn out. A rotisserie option is available for even more cooking production with minimal operator attention.

Look to American Range for innovation, reliable performance and quality, now and for all your future commercial cooking equipment needs.

DESIGNED & BUILT IN USA  
PROFESSIONAL COOKING EQUIPMENT

[www.americanrange.com](http://www.americanrange.com)



# AHS HORIZONTAL CHICKEN BROILERS

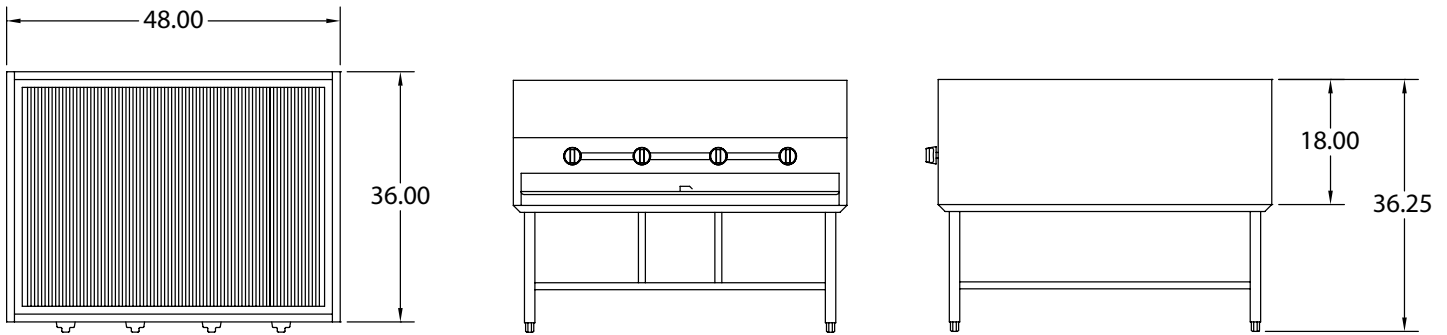

Model	Width	Depth	Height	Burners	Total BTU	KW	Shipping Weight	Lbs.	Kg.
AHS-4827	48"	27"	22"	4	160,000	47		270	122
AHS-6027	60"	27"	22"	5	200,000	59		370	167
AHS-4836	48"	36"	22"	4	160,000	47		300	136
AHS-6036	60"	36"	22"	5	200,000	59		400	181
AHSR-48	48"	36"	36"	4	160,000	47		400	181
AHSR-60	60"	36"	36"	5	200,000	59		500	226

## STANDARD FEATURES

- Stainless Steel rugged exterior.
- Large 36" deep broiling surface.
- Round rod non-stick cooking top grates specially designed for chicken broiling.
- High BTU for even heat distribution assures fully cooked chickens.
- Open bottom grate design allows continuous up draft for optimum fuel combustion.
- Rotisserie option allows more cooking production with minimal operator attention.
- Heavy duty liner protects interior from burn out.
- One year limited warranty, parts and labor.

## OPTIONAL FEATURES

- Spit fork, 2 prong, Stainless Steel.
- Spit fork, double 2 prong, Stainless Steel.
- Spit rod and handle.
- Spit rod assembly complete with handle and prongs.
- Built-in Rotisserie.

## STAINLESS STEEL STANDS

- HESS-4827 - 50 LBS. (23) kg.
- HESS-6027 - 57 LBS. (26) kg.
- HESS-4836 - 65 LBS. (30) kg.
- HESS-6036 - 80 LBS. (36) kg.

**GAS SUPPLY:** 3/4" NPT Gas inlet. Manifold pressure is 5.0"W.C. for natural gas or 10.0"W.C. for propane gas. Specify type of gas and altitude if over 2000 feet.

**CLEARANCES:** For use only on non-combustible floors. Legs or casters are required, or 2" (51) overhang is required when curb mounted. Clearance from non-combustible walls is 0". When unit is placed next to combustible walls, clearances must exceed 12" (305) on sides, and 4" (102) from rear. Radiant broilers for non-combustible locations only.

American Range is a quality manufacturer of commercial cooking equipment. Because of continuing product improvements these specifications are subject to change without prior notice.